

Level Measurement Expert

TNUD Ultrasonic Level Transmitter



**Prisma Instruments**

89 rue du Vallat 13400 Aubagne FRANCE

Tel. : +33 (0)4 42 70 74 04

Fax : +33(0)4 42 70 38 647

contact@prisma-instruments.com

## INTRODUCTION

The ultrasonic level transmitter is a non-contact, low-cost and easy-to-install measuring device. It can be applied to most industrial applications for both solids and liquids. Most important aspect of it is that it is easy-to-install and low maintenance due to no moving parts.

### WORKING PRINCIPLE

During operation, the device emits a wave to the medium to be measured. The wave reflects off the surface and moves back to the device where a transducer calculates the distance. The distance is based on the time interval between transmission and reception of the wave.  $D = (334.1 + 0.6t) \times T/2$ , where the D = the transmission distance; t = temperature; and T = transmission time.

With 4~20mA output, it can be connected to the PLC, DSC and SCADA systems. In addition, it is also equipped with exclusive PULSE and AGC (Auto Gain Control) echo tracking technology to ensure accuracy and precision even in the harshest environments.

### FEATURES

- 4~20mA 2 wire output (Fully isolated) with HART
- 7~30Vdc power supply
- IP67 protection casing
  
- Transducer material: PVDF
- False echo detection
  
- Internal temperature compensation.
- Beam angle: 7°
- Not affected by liquid temperature, S.G, viscosity
- Maximum range to 12 meters(40 ft).

### MAIN FUNCTIONS

- Level measurement
- Object distance measurement
- Volume measurement

### COMPACT DESIGN

Compact size: equipped with 4 push buttons, Multi-parameters modes and a LCD display.

### USER FRIENDLY OPERATION

Can be configured for Imperial or Metric system units.

### RAPID RESPONSE

It can detect level moving up to 10m/min making it one of the industry's quickest.

### EXTENSIVE APPLICATIONS

The PVDF transducer is ideal for use in corrosive applications.

### FALSE ECHO

Selectable FER function which enables the instrument to identify obstructions within the path of the ultrasonic beam, memorizes their position and ignores them during the measuring process.

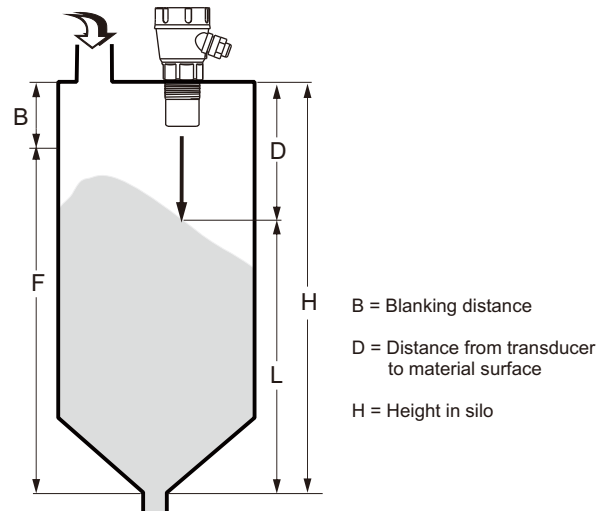

## APPLICATIONS

1. Water or waste water treatment equipment: pumps, open channels, dams and wells.
2. Edible-oils, sauces and beverages.
3. Chemicals: paints, carbons, water, crude oil, epoxy resin, lime slurry and wax.
4. Diesel, Petrochemicals, alcohols, solvents etc.

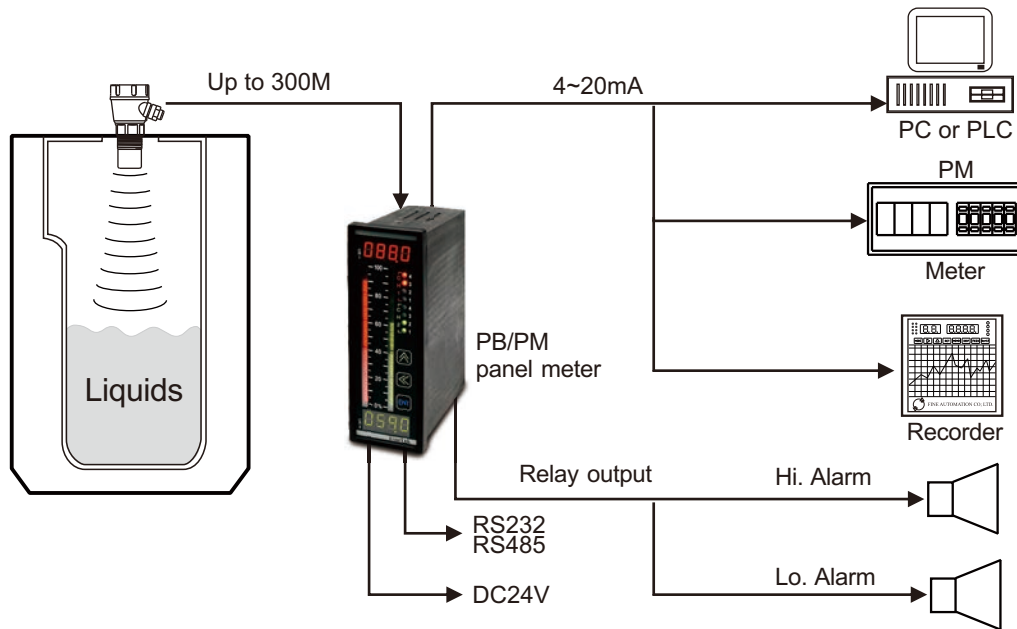

Liquid measurement

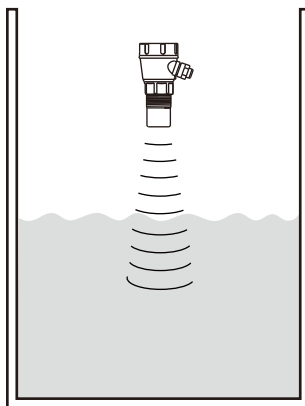

Silo with rotational aiming kit

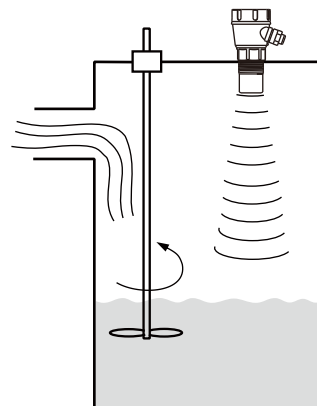

## SPECIFICATIONS

<b>Frequency</b>	50 kHz
<b>Operating Voltage</b>	7 - 30VDC at the terminal (residual ripple no greater than 100mV)
<b>Power Consumption</b>	500mW @ 24VDC
<b>Analog Output</b>	4-20mA modulating output module with HART (Recommended 250 Ohm @ 24VDC)
<b>Analog Resolution</b>	14 bits
<b>Communications</b>	4-20mA with HART
<b>Blanking Distance</b>	250 mm (10 inch)
<b>Maximum Range</b>	12 metres (-40~60°C)
	8 metres (-40~70°C)
<b>Resolution</b>	1 mm (0.04")
<b>Electronic Accuracy</b>	+ / - 0.25% of maximum range
<b>Operating Temperature</b>	- 40°C~70°C
	LCD temperature : - 40°C~60°C
<b>Maximum Operating Pressure</b>	- 0.5 to 3 bar
<b>Beam Angle</b>	7°
<b>Materials</b>	Transducer: PVDF Housing: Powder coated aluminium
<b>Display</b>	4 line graphic display
<b>Keypad</b>	4 keys = CAL, RUN, UP, DOWN
<b>Memory</b>	>10 years data retention
<b>Enclosure Sealing</b>	IP67
<b>Cable Entries</b>	M20 cable glands
<b>Mounting</b>	2" BSPT Thread 2" NPT Thread
<b>Typical Weight</b>	1kg (2.2 pounds)

# INSTALLATION

## 2-wires (power supplied by panel meter)

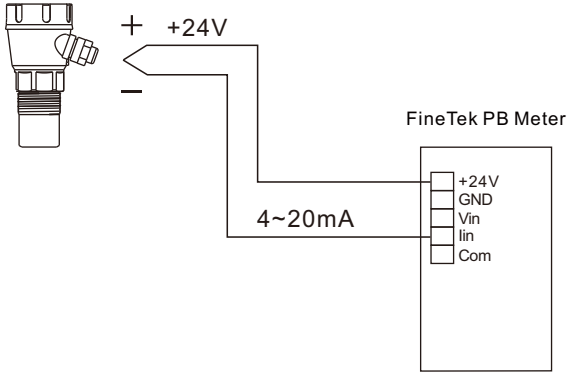

The ultrasonic transducer is mounted to the flange of the extension nozzle of the tank. Please refer to the instruction below:

Length for dead band:

Dead band has to be 150mm over extension nozzle .  
Dead band needs to be set as 500mm if extension nozzle is shorter than 500mm.

Extension length:

Please refer to below table and choose the suitable probe

Flange size	Diameter of extension nozzle ( $\phi$ )Min	Diameter of extension nozzle (Max)
3"	75mm	300mm
4"	100mm	300mm
6"	150mm	400mm
8"	200mm	600mm
12"	300mm	600mm

## 2-wires power supply (external)

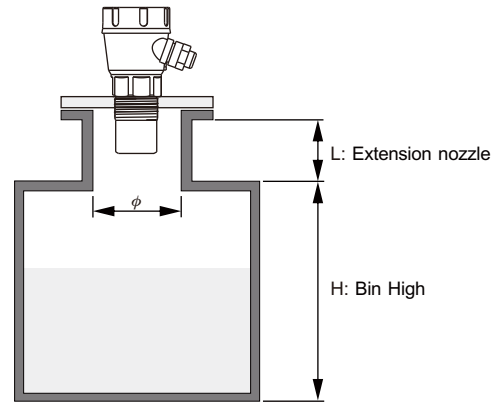
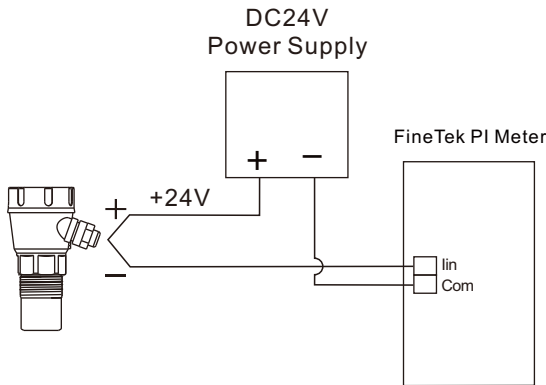

## 4-wire (PLC)

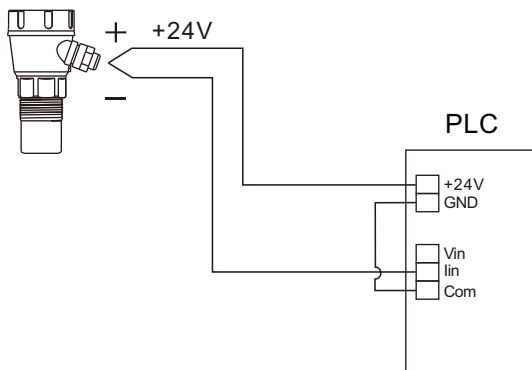

## CAUTION BEFORE INSTALLATION

Keep the transducer perpendicular to the liquid surface.

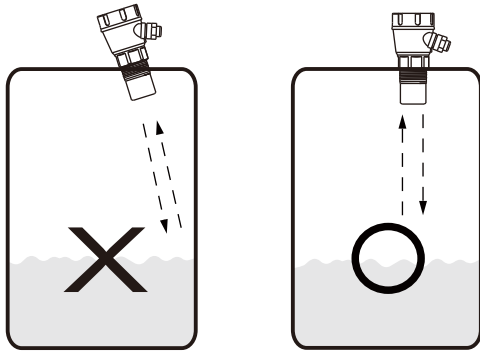

The transducer should not be mounted too close to the tank wall to avoid interference.

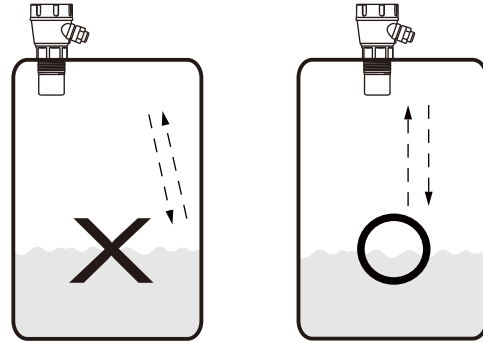

A pipe surrounding the detection path along the ultrasonic wave from emitting to receiving is Recommended. Installation can prevent false signals caused by turbulence and foam when an agitator is present. When the pipe is installed, a vent hole is required to balance the pressure difference between the inside and outside of the pipe...

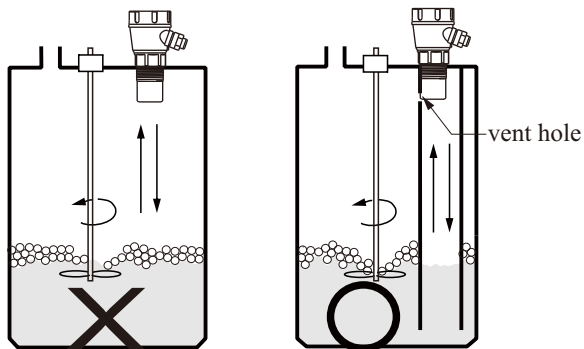

Do not mount the device close to the tank wall.

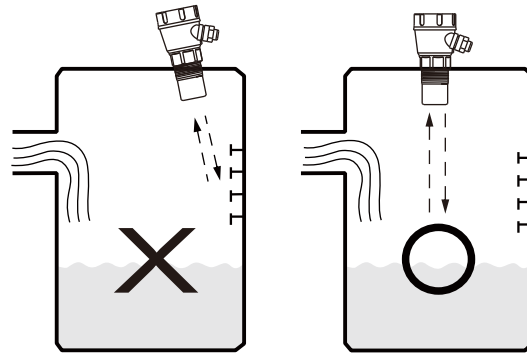

Mount the transducer away from the inlet to avoid interference with the medium.

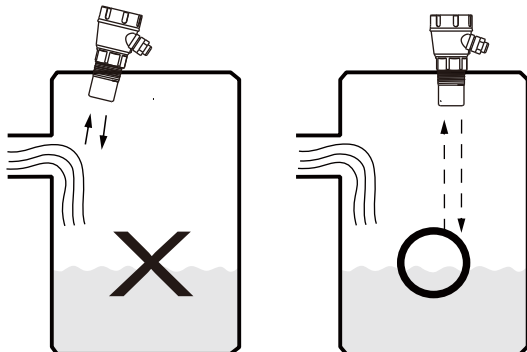

When the user mounts the transducer on a solid tank, the transducer must not point to the outlet of tank.

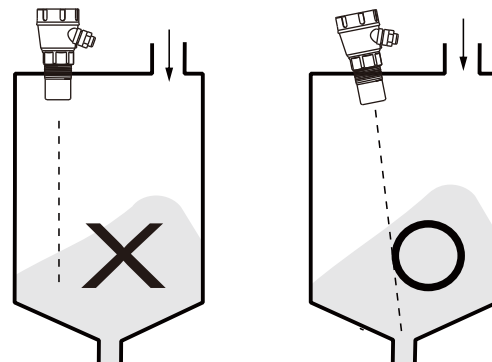

## DIMENSIONS / ORDERING INFORMATION

### Dimensions

(Unit:mm)

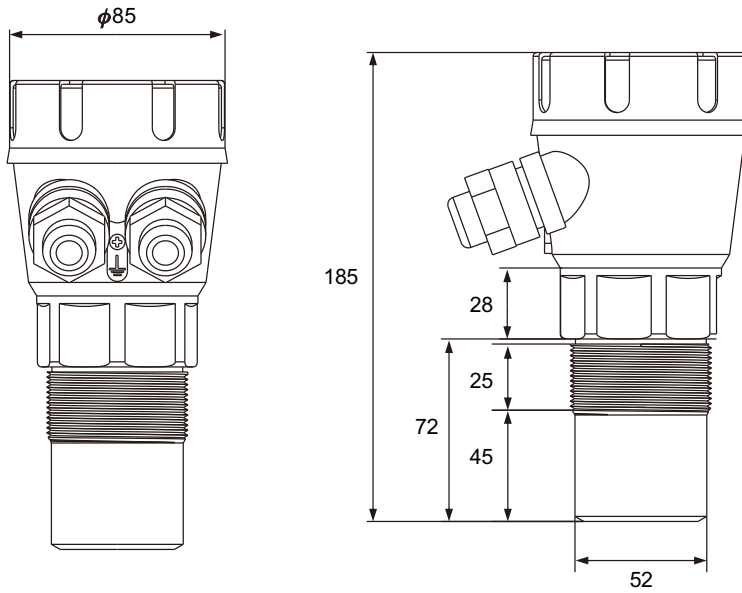

### Ordering information

TNU 20000 -A 10 11 12 13

Connection

10 11

B2: 2"

12 13

07: NPT male

91: BSPT male

Level Measurement Expert

---

Prisma Instruments  
Expertise & Industrial Solutions

Prisma Instruments  
89, rue du Vallat 13400 Aubagne  
FRANCE

Tel. : +33 (0)4 42 70 74 04  
Fax : +33 (0)4 42 70 38 64  
@ : [contact@prisma-instruments.com](mailto:contact@prisma-instruments.com)